

DRIVE▶RITE

an **AMK** company

Unit 626 Kilshane Avenue, North West Business Park, Ballycoolin, Dublin 15, Ireland
Telephone: +353 1 8612 632 Fax: +353 1 8612 647 email: info@driveriteair.com
Web: www.driveriteair.com

DR.02.014000

MB SPRINTER (509-524)/ VW CRAFTER (50)

ABS Vehicles Only

INSTALLATION INSTRUCTIONS



Table of Contents

Table of Contents	2
Introduction	3
IMPORTANT SAFETY NOTICE.....	3
Special Instructions for Air Connections	3
Kit Contents	4
HARDWARE LIST.....	4
Step by Step Installation	5
Step 1: Remove the Bump Stop	5
Step 2: Upper Bracket to Chassis	6
Step 3: Lower Bracket/Air Spring assembly to Vehicle	6
Step 4: Air Spring Assembly to Upper Bracket.....	9
Step 5: Adding a Heat Shield, if needed.....	10
Step 6: Routing the Air Tubing	12
Appendix 1	13
Notes	15

Introduction

The purpose of this publication is to assist with the installation of the Drive-Rite Semi-Air air suspension kit.

It is important to read and understand the entire installation guide before beginning installation or performing any maintenance, service or repair. The information here includes a hardware list and step-by-step installation information.

Drive-Rite reserves the right to make changes and improvements to its products and publications at any time. Contact Drive-Rite at +353 1 8612 632 or visit us online at www.driveriteair.com for the latest version of this manual.

IMPORTANT SAFETY NOTICE

The installation of this kit does not alter the Gross Vehicle Weight Rating (GVWR) or payload of the vehicle. Check your vehicle's owner's manual and do not exceed the maximum load listed for your vehicle.

Gross Vehicle Weight Rating = the maximum allowable weight of the fully loaded vehicle (including passengers and cargo). This number — along with other weight limits, as well as tire, rim size and inflation pressure data — is shown on the vehicle's Safety Compliance Certification Label.

Payload: The combined, maximum allowable weight of cargo and passengers that the truck is designed to carry. Payload is GVWR minus the Base Curb Weight.

Precautions

Never exceed the maximum and minimum recommended pressure limits:

- Minimum Pressure 1 Bar (14.5 p.s.i)
- Maximum Pressure 7 Bar (100 p.s.i)

While it is possible to inflate the system in static mode to 7 Bar (100 p.s.i.), it should not be necessary to exceed operating pressure in the region of 3.5 Bar (50 p.s.i.) at vehicle full GVW. This kit should not be used to carry any greater load than manufacturers stated GVW.

To avoid damage to airsprings – When the kit has been installed, please ensure there is adequate clearance (25mm) around the airspring so the airspring does not come in contact with any other parts.

NEVER DRIVE WITH DEFLATED AIRSPRINGS

Special Instructions for Air Connections

- To cut the tubing correctly an appropriate cutter must be used (not scissors)



- When inserting the tubing into the connection, it must be pushed in approximately 14mm until a 'click' is heard.
- To remove the tube, you must push the flange in on the connection and at the same time pull the tube. (No tool is necessary.)
- **ATTENTION**, when a tube is removed it is important to trim 14mm from the end before reconnection.
- It is advisable that LOCTITE or similar sealant be used on the threaded fittings.

Kit Contents

▼ HARDWARE LIST

Description	Quantity	Picture/Description	Part #
Upper Bracket	2		DRV-7250
Lower Brackets	1 short & 1 long		DRV-7471 & DRV-7472
Axle Clamp	2		DRV-7474
Spacer Plate	2		DRV-7249
Upper Clamp Plate	2		DRV-7248
Axle Spacers	2 (Handed)		DRV-7473
M10 x 20 Countersunk Bolts	4	Upper Bracket to vehicle	0089
1/2" x 1" UNC Countersunk Bolts	2	Lower Bracket to Air Spring	0024
M12 Flat Washer	8	For Axle Clamp	0128
M12 Nyloc Nut	4	For Axle Clamp	0141
M12 x 30 Bolt	4	For Axle Clamp	3825
Cable Ties	6		9037
M8 Flat Washer	4	Inflation valves	0007
M6 x 12 Countersunk Bolts	4	Spacer to Lower Bracket	0144
Xenon relocation bracket	1		DRV-7800
M6 X 20 Hex Head Bolt	4		0003
M6 Flat Washer	8		0008
M6 Nyloc Nut	4		0014
Spacer Disc	2		DRV-7040
3/8-24 FLANGE NUT	4	Upper Bracket to Air spring (only for DR.07.027339 with studs)	DR.43.013023
3/8"-16 UNC x 3/4" Flanged Hex Bolt	4	Upper Bracket to Air spring (only for DR.07.017339 with blind nuts)	DR.42.013069
Style 26 Airspring	2	Double Convolute	7339
Thermal Sleeves	2		0899
6mm Elbow	2		3614
6mm Inflation valve	2		3660
6mm Tee piece	1		3666
6mm Tubing	5		1364-1MB

Step by Step Installation

Step 1: Remove the Bump Stop

Remove the original bump stops located above the rear axle.

Option 2: Depending on vehicle variant, optional bump stops may be located on the axle (as circled in dashed line). These will also need removing.

Note: There is an internal bump stop in the air springs and these will replace the original bump stops.

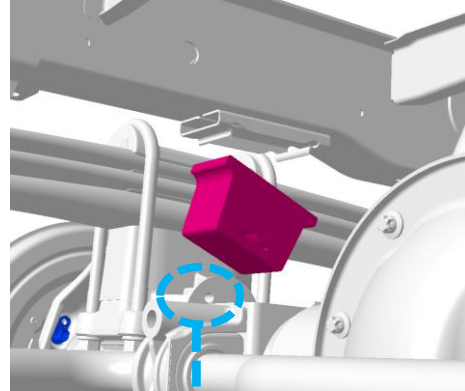

Cut the latches off the axle with an angle grinder or a hack saw as per the picture on the right.

Treat the cut surface with a protection primer to avoid rust.

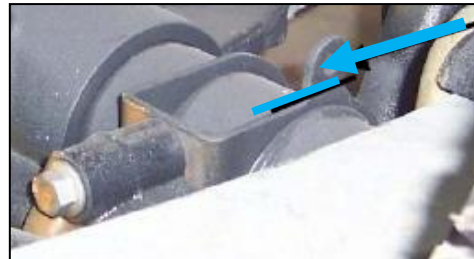

Slide the Upper Clamp Plate over the original bump stop location as shown.

Ensure this plate is inserted from the rear of the vehicle.

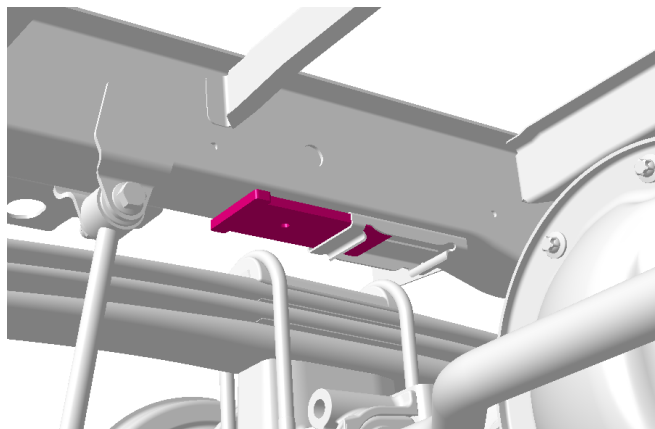

↘ Step 2: Upper Bracket to Chassis

Note: If vehicle is fitted with self-levelling xenon lights please refer to Appendix 1: Xenon Lights

Before the Upper Brackets can be bolted onto the Upper Clamp Plate, a Spacer Plate must be placed under the Upper Clamp Plate as shown.

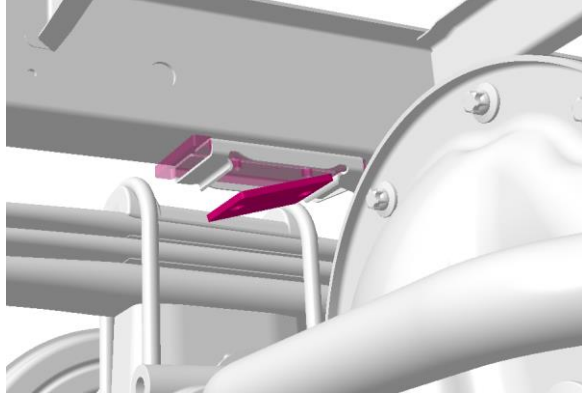

Fasten the Upper Brackets including the Spacer Plate to the Upper Clamp Plate. Ensure the two flanges are facing **inboard towards the centre of the vehicle**.

Secure in place using the M10x1.5-20 countersunk bolts.

(Torque to approx. 38Nm)

***If vehicle is fitted with Xenon sensor please see Appendix 1.**

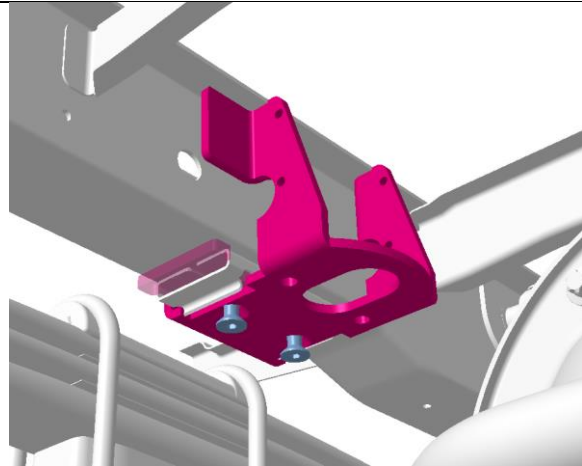

↘ Step 3: Lower Bracket/Air Spring assembly to Vehicle

Bolt the Lower Brackets to the Air Springs using the ½" x 1" countersunk bolts. **Ensure the Spacer Disc is inserted between the Air Spring and the Lower Bracket.**

(Torque to approx. 40Nm)

Fasten the Air Springs to the Upper Brackets using the 3/8"-16 x ¾" flange bolts. *(Torque to approx. 22Nm)*

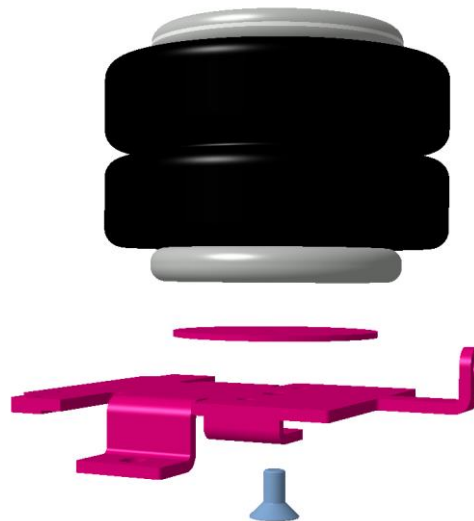

The Lower Bracket is secured to the axle using the Axle Straps and the M12 x 30 bolts, washers and locknuts.

(Torque to approx. 87Nm)

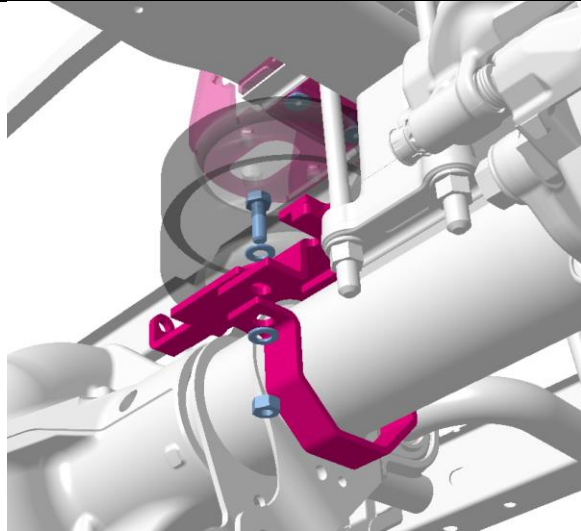

When installing the Lower Bracket it must be seated between the 2 U-bolts. The small spacer block should be resting on the axle on both sides.

If a gap occurs such as the one in the picture on the right then remove the lower bracket and bolt the loose 6mm axle spacers to the lower bracket on each side using 2 x M6 countersunk bolts as shown. *(Torque to approx. 40Nm)*

Note: *The axle spacers are handed.*

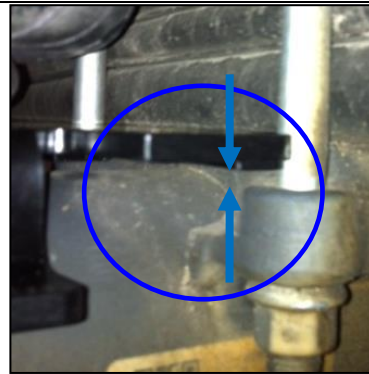

Without Spacer



With Spacer

Option 2:

If vehicle variant is fitted with extended leaf spring spacers, it will firstly be necessary to rotate these by 180 degrees before fitting lower bracket/air spring assembly.

Start by independently supporting axle from the vehicle.

Take note of correct positioning of u-bolts & leaf spring saddle for refitting later. You will then need to remove u-bolts to release spacers.

Retain the u-bolts and nuts to re-fit later.

Once u-bolts are removed, carefully lower the axle enough to lift spacers & rotate by 180 degrees. Ensure locating pins (marked in upper image with a dashed circle) are correctly lined-up with holes in spacers.



Original position of extended leaf spring spacer

Secure braking sensor cables to rotated leaf spring spacers (shown in red circle) to ensure no contact with moving parts on hub assembly.

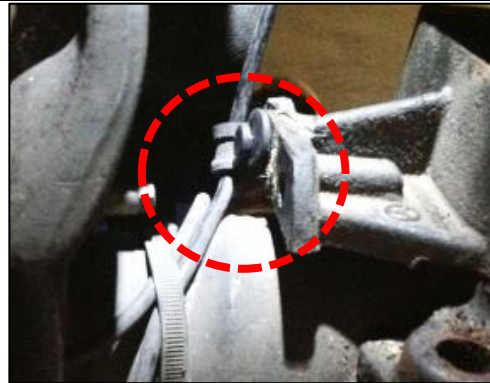

Position of extended leaf spring spacer once rotated 180 degrees

Re-fit u-bolts ensuring no gap between spacer & leaf springs (area shown by green dashed).

Torque the nuts and u-bolts to 130Nm.



Removal of U bolts

↘ **Step 4: Air Spring Assembly to Upper Bracket**

Fasten the Air Springs to the Upper Brackets.

If the air spring has blind nuts as shown (DR.07.017339), use the 3/8"-16 x 3/4" Flange Bolts provided. (Torque to approx. 22Nm)

If the air spring has studs (DR.07.027339), use the 3/8"-24 Flange Nuts provided.

The Lower Bracket is secured to the axle using the Axle Straps and the M12 x 30 bolts, washers and locknuts. (Torque to approx. 40Nm)

Insert the Elbow fitting into the Air Spring as shown in the image.

To help to ensure a tight seal, it is recommended that sealant is used.



Step 5: Adding a Heat Shield, if needed.

If the exhaust is running close to the air spring as shown in the picture on the right then it may be necessary to use a heat shield to protect the air spring. **The heat shield is not supplied in the basic kit. The part number is DR.45.011004.**



Bend the heat shield middle tab out at a 90 degree angle and bend the heat shield again half the distance up the tab at a 90 degree angle to form a "L" shape as shown in Figure "A".

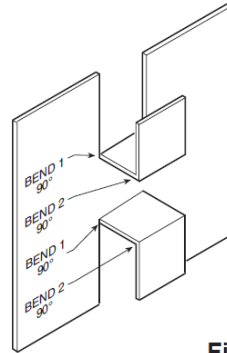

Figure "A"

Mount the heat shield between the air spring and the exhaust pipe. Mount the heat shield using the clamps provided see Figure "B". **Maintain clearance between heat shield and moving axle, lines, etc...**

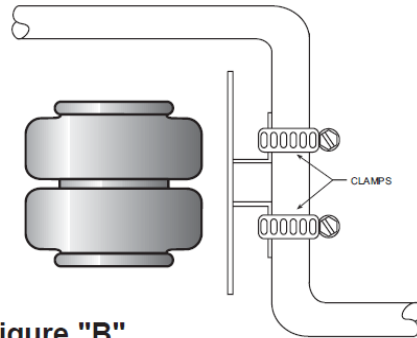

Figure "B"

Bend the heat shield around the exhaust pipe, while allowing for open air space of 15mm to 25mm.

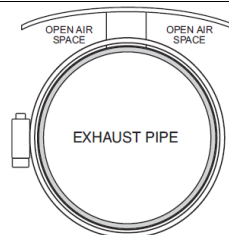
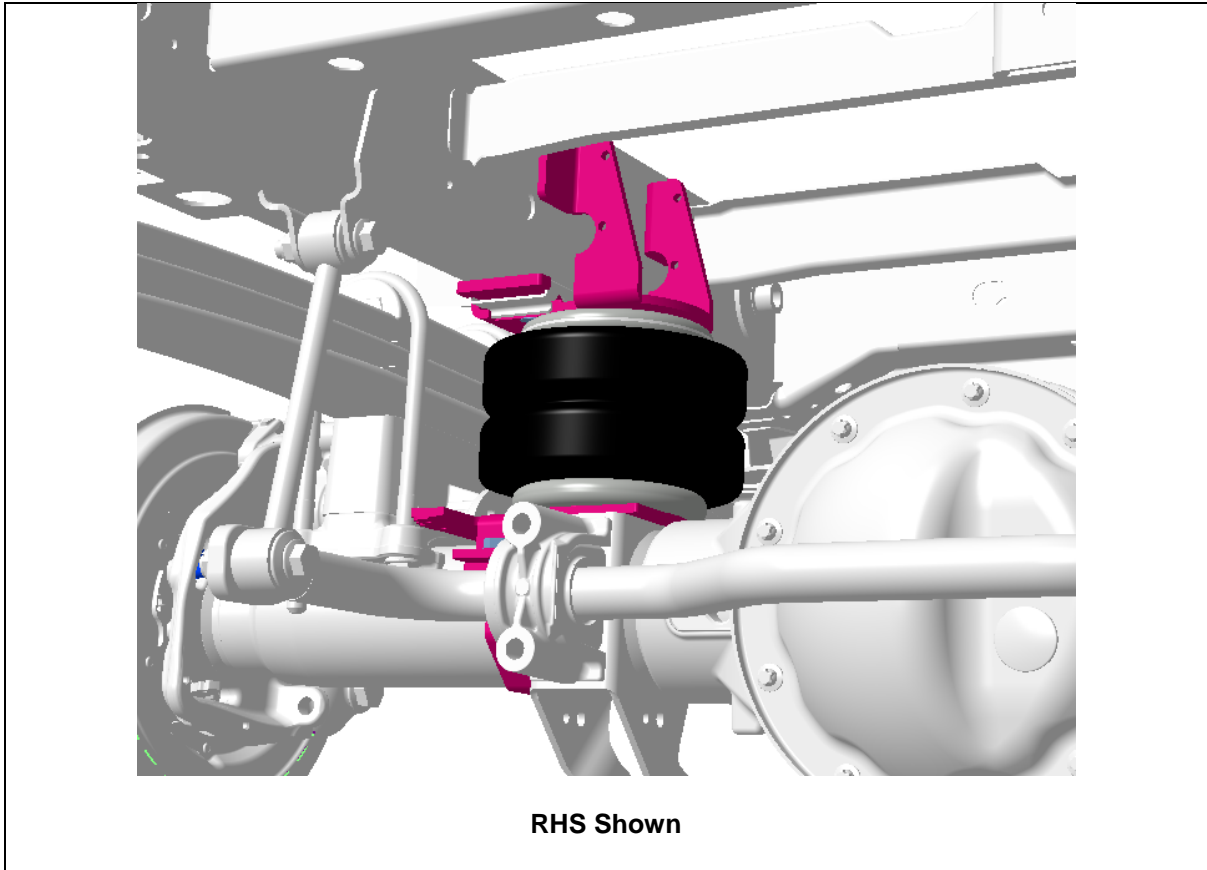
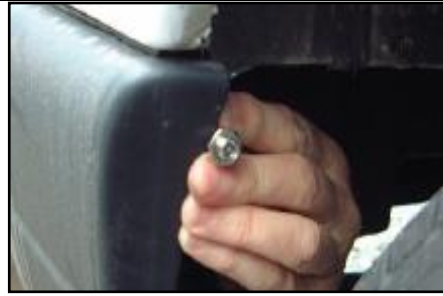

Figure "C"



Step 6: Routing the Air Tubing

Cut a long length of tubing in order to connect the valve to the nearest air spring. Do the same for the opposite side. Choose whether you want separate inflation valves for each side or one valve common to both sides using the T shaped connector. Use the nylon ties provided to tie the tubing up into a safe position.



When cutting the air tube, it is vital that the tube is not cut at an angle. This could cause an air leak. It is recommended that a tube cutter or a sharp blade be used.



Drill an 8mm (5/16") hole and mount the inflation valve as shown in the diagram, pushing the valve through the hole from behind and attaching with 2 washers and a nut.

Cut the air tube to length, making sure the end is cut squarely, and push the end as far as possible into the back of the inflation valve.

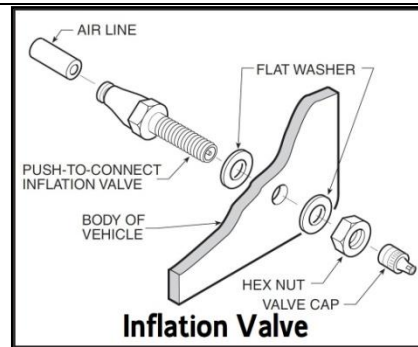

IMPORTANT:

- Attach all tubing securely to the underneath of the vehicle using nylon ties.
- Do not attach to brake lines.
- Protect the tube with the sleeves provided where there are any sharp edges or sources of heat.
- Secure all fixings to the recommended torque settings.

Examination:

After assembly, inflate air springs and check all mounting bolts are tight. Screw all connections tight again. It must be ensured that the mounting brackets cannot move. If the plates touch the brake hose at the air springs, then these must be moved by suitable means.

Appendix 1

For vehicles fitted with self levelling headlights the steps below should be followed.

Note: Diagrams are indicative of a 4x4 vehicle. The same steps should be taken for 4x2 variants.

Unplug sensor from vehicle wiring loom.

Remove 2 x M6 nuts holding sensor to vehicle.

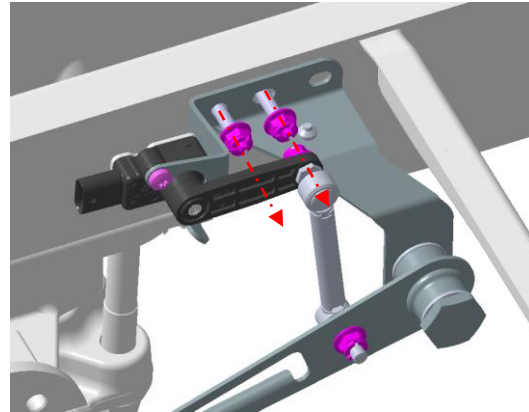
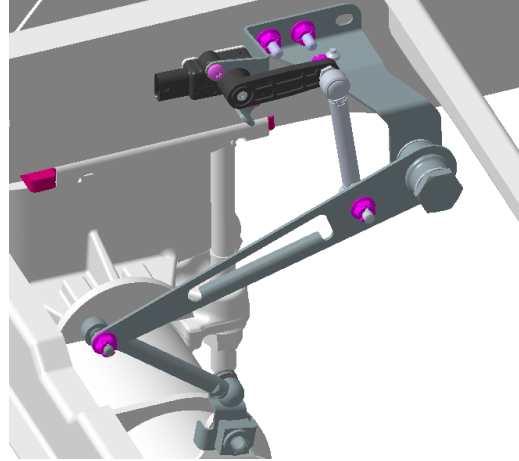

Cut the M6 studs to be flush with the chassis.

***Treat with anti-corrosion primer & paint.**

***Refer to latest revision of Mercedes Bodybuilder Guidelines for anti-corrosion protection measures.**

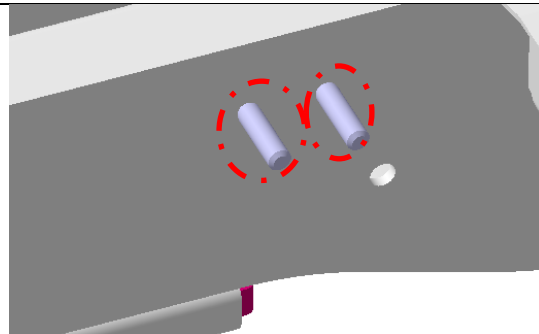

Complete Steps 2-5

Mount the newly supplied bracket to the upper bracket using M6 X20 bolt, washers and nyloc nuts provided.

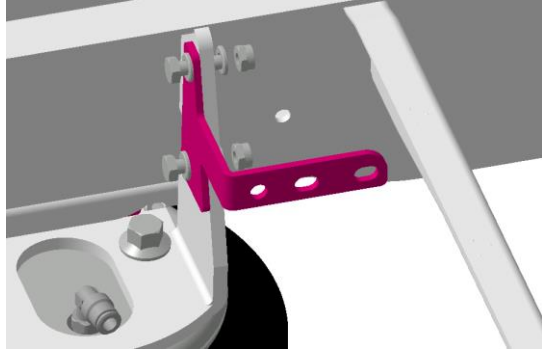

Bolt sensor bracket to relocation bracket using M6 X20 bolt, washers and nyloc nuts provided

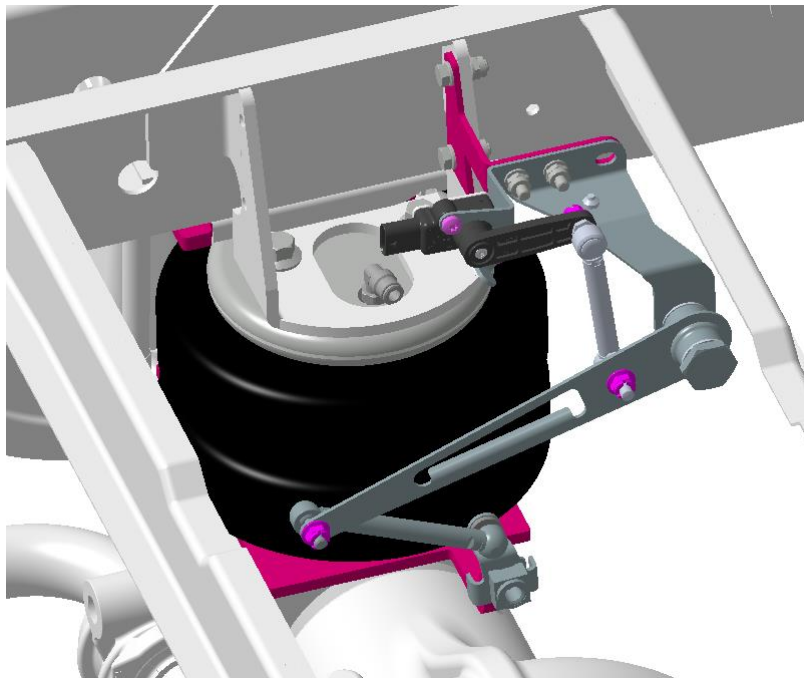
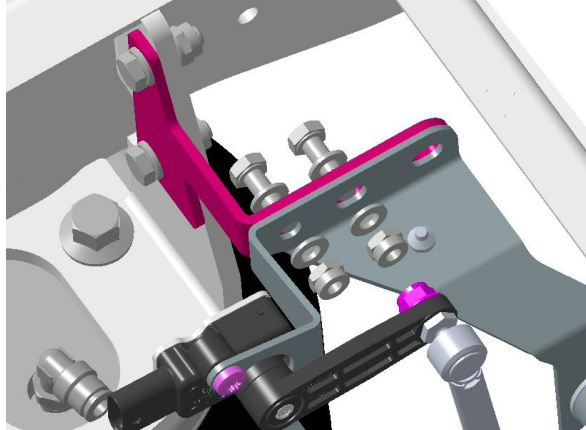

TÜV SÜD AUTOMOTIVE GMBH Westendstrasse 199 D-80686 München		 Automotive
Teilegutachten Nr.:	13-00291-CX-GBM-00	
Hersteller:	DRIVERITE Ltd.	
Typ:	DR.02.014...	Seite 1 von 7

TEILEGUTACHTEN
Nr. 13-00291-CX-GBM-00
TGA-Art: 8.1

über die Vorschriftsmäßigkeit eines Fahrzeuges bei bestimmungsgemäßem Ein- oder Anbau von Teilen gemäß § 19 Abs. 3 Nr. 4 StVZO

für das Teil / den Änderungsumfang : Zusatz-Luftfedersystem

vom Typ : DR.02.014...

Ausführungen: : DR.02.014000 / DR.11.012196
DR.02.014000 / DR.11.026534
DR.02.014000 / DR.11.006110
DR.02.014000 / DR.11.012236
DR.02.014000 / DR.11.006112
DR.02.014000 / DR.11.012436
DR.02.014000 / DR.11.012332

des Herstellers : DRIVERITE Ltd.
Unit 626 Kilshane Avenue, North West Business Park
Ballycoolin IRL - 15 Dublin

für das Fahrzeug : Mercedes Sprinter / VW Crafter

0. Hinweise für den Fahrzeughalter

Unverzügliche Durchführung und Bestätigung der Änderungsabnahme:
Durch die vorgenommene Änderung erlischt die Betriebserlaubnis des Fahrzeuges, wenn nicht unverzüglich die gemäß StVZO § 19 Abs. 3 vorgeschriebene Änderungsabnahme durchgeführt und bestätigt wird oder festgelegte Auflagen nicht eingehalten werden!
Nach der Durchführung der technischen Änderung ist das Fahrzeug unter Vorlage des vorliegenden Teilegutachtens unverzüglich einem amtlich anerkannten Sachverständigen oder Prüfer einer Technischen Prüfstelle oder einem Prüferingenieur einer amtlich anerkannten Überwachungsorganisation zur Durchführung und Bestätigung der vorgeschriebenen Änderungsabnahme vorzuführen.

Einhaltung von Hinweisen und Auflagen:
Die unter III. und IV. aufgeführten Hinweise und Auflagen sind dabei zu beachten.

Mitführen von Dokumenten:
Nach der durchgeführten Abnahme ist der Nachweis mit der Bestätigung über die Änderungsabnahme mit den Fahrzeugpapieren mitzuführen und zuständigen Personen auf Verlangen



TÜV Certificate Available, contact Drive-Rite for details

DRIVERITE

AIR SUSPENSION SYSTEMS

Unit 626 Kilshane Avenue, North West Business Park, Ballycoolin, Dublin 15, Ireland

Telephone: +353 1 8612 632 Fax: +353 1 8612 647 email: info@driveriteair.com

Web: www.driveriteair.com